

PLAN OF SUBDIVISION

PS 728974W/S3

LOCATION OF LAND

Parish : JIKA JIKA
City of Brunswick

Section : A

Crown Allotment : 48, 49 & 49A (PARTS)

Crown Portion : -

Title Reference :

Last Plan Reference : PS728974W, Lot S4

Postal Address : 8-12 OLIVE YORK WAY
(at time of subdivision) BRUNSWICK WEST VIC 3055

MGA Co-ordinates E 318 523 ZONE : 55
(of approx. centre of land in plan) N 5 818 898

COUNCIL NAME: MORELAND CITY COUNCIL

VESTING OF ROADS AND/OR RESERVES

IDENTIFIER	COUNCIL/BODY/PERSON
NIL	NIL

NOTATIONS

BOUNDARIES SHOWN BY THICK CONTINUOUS LINES ARE DEFINED BY BUILDINGS.
LOCATION OF BOUNDARIES DEFINED BY BUILDINGS:

MEDIAN: BOUNDARIES MARKED 'M'
INTERIOR FACE: ALL OTHER BOUNDARIES

NOTATIONS

DEPTH LIMITATION: 15.24 METRES BELOW THE SURFACE

ALL INTERNAL SERVICE DUCTS, PIPE SHAFTS AND COLUMNS WITHIN THE BUILDING ARE DEEMED TO BE PART OF COMMON PROPERTY No.1. NOTE THAT THE POSITIONS OF THESE DUCTS, SHAFTS AND COLUMNS HAVE NOT NECESSARILY BEEN SHOWN ON THE DIAGRAMS CONTAINED HEREIN.

ALL COMPONENTS OF THE VAPOUR MANAGEMENT SYSTEM, INCLUDING BARRIERS, PIPES AND VENTS ARE DEEMED TO BE PART OF COMMON PROPERTY No.1. THE POSITION OF THESE COMPONENTS HAVE NOT BEEN SHOWN ON THE DIAGRAMS CONTAINED HEREIN.

LOTS ON THIS PLAN MAY BE AFFECTED BY ONE OR MORE OWNERS CORPORATIONS. SEE OWNERS CORPORATION SEARCH REPORT(S) FOR DETAILS.

COMMON PROPERTY No.1 IS ALL THE LAND IN THE PLAN EXCEPT LOTS DLG01-DLG06, DG01-DG17, D101-C117, D201-D217, D301-D317, D401-D417, D501-D514, DPH01-DPH13, DPH18, S3 AND COMMON PROPERTY No.3.

CP1 COMMON PROPERTY No.1
CP3 COMMON PROPERTY No.3
BAL BALCONY
CY COURTYARD

LOTS DPH14, DPH15, DPH16, DPH17 HAVE BEEN OMITTED FROM THIS PLAN.

Survey : THIS PLAN IS BASED ON SURVEY.

Staging : THIS IS A STAGED SUBDIVISION
PLANNING PERMIT No. SP/2015/138

To be completed where applicable:
THIS SURVEY HAS BEEN CONNECTED TO PERMANENT MARKS No(s)
IN PROCLAIMED SURVEY AREA No.

EASEMENT INFORMATION

LEGEND: A – APPURTENANT EASEMENT E – ENCUMBERING EASEMENT R – ENCUMBERING EASEMENT (ROAD)

SECTION 12 (2) OF THE SUBDIVISION ACT 1988 APPLIES TO ALL OF THE LAND IN THIS PLAN

EASEMENT REFERENCE	PURPOSE	WIDTH (Metres)	ORIGIN	LAND BENEFITED/IN FAVOUR OF
E-1	CARRIAGEWAY	9.61	PS606542K	LOT 3 ON PS606542K

CHARTER.
KECK CRAMER

Level 19/8 Exhibition Street, Melbourne Victoria 3000
Telephone 03 8102 8888 www.charterkc.com.au

SURVEYOR'S REF: J023976/S3

19/10/16

ORIGINAL SHEET SIZE: A3

SHEET 1 OF 20

KEVIN J. BARGE LS

VERSION 13

DIAGRAM 1
BASEMENT LEVEL

SEE SHEETS 3 - 6 FOR FURTHER
DETAILS OF LOTS ON THIS SHEET

MGA94 ZONE 55

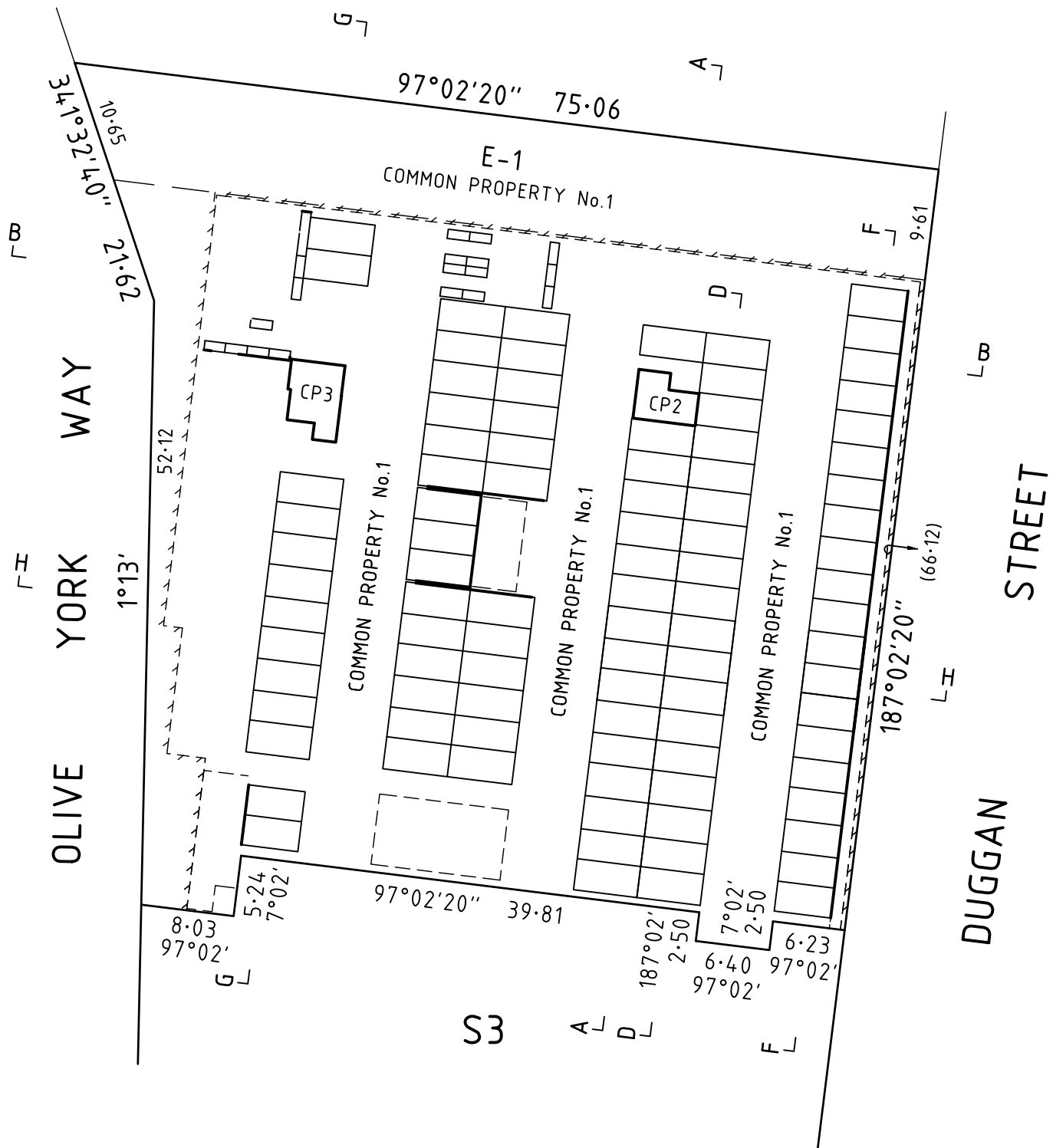

SURVEYOR'S REF: J023976/S3

CHARTER.
KECK CRAMER

Level 19/8 Exhibition Street, Melbourne Victoria 3000
Telephone 03 8102 8888 www.charterkc.com.au

SCALE
1:500

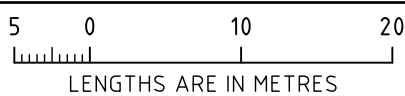

ORIGINAL SHEET SIZE: A3

SHEET 2

KEVIN J. BARGE LS
VERSION 13

DIAGRAM 2
BASEMENT LEVEL - NORTH

PS 728974W/S3

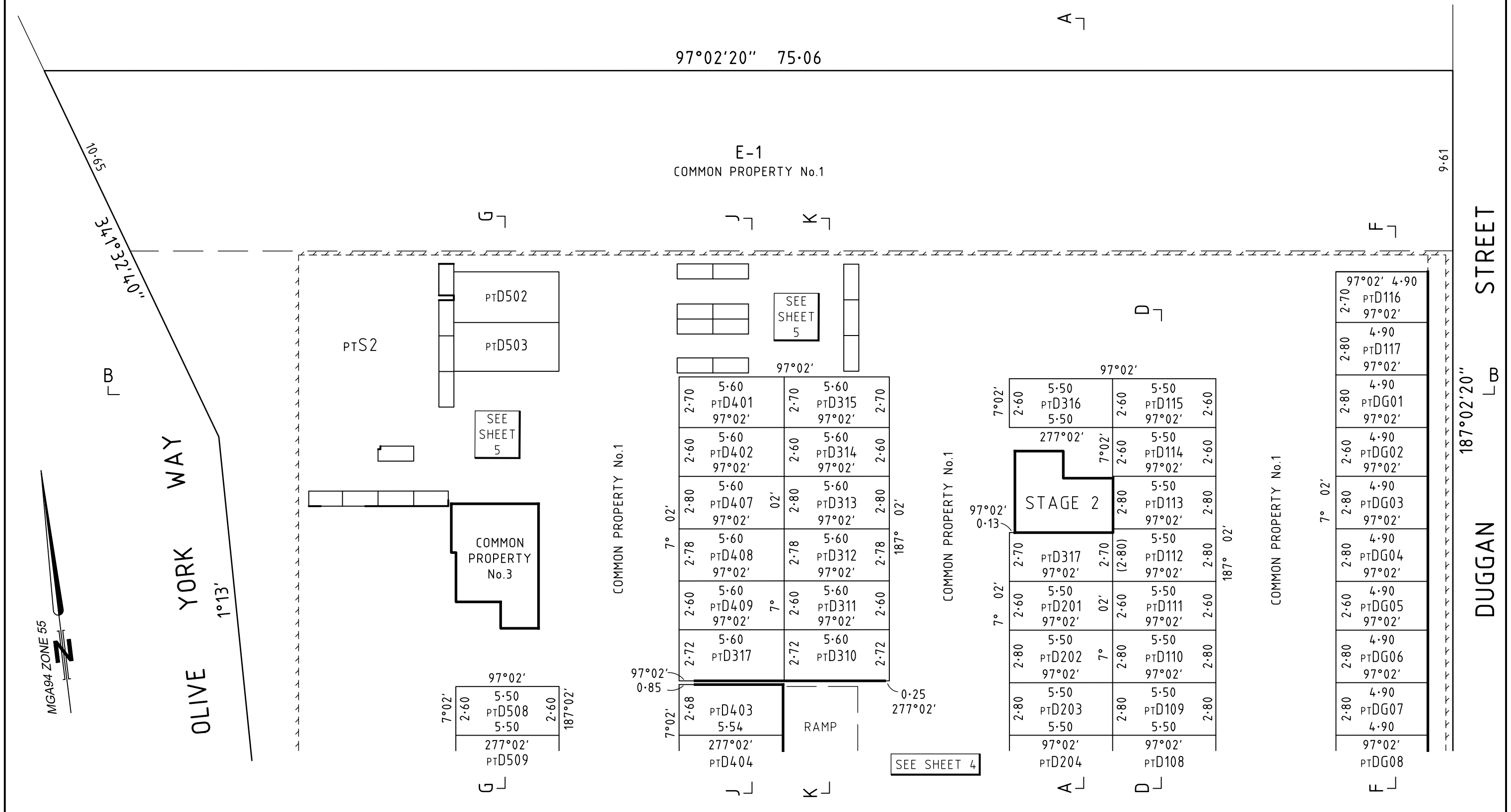

SURVEYOR'S REF: J023976/S3

CHARTER.
KECK CRAMER

Level 19/8 Exhibition Street, Melbourne Victoria 3000
Telephone 03 8102 8888 www.charterkc.com.au

SCALE
1:200



ORIGINAL SHEET SIZE: A3

SHEET 3

KEVIN J. BARGE LS

VERSION 13

DIAGRAM 4
BASEMENT LEVEL - ENLARGEMENT 1

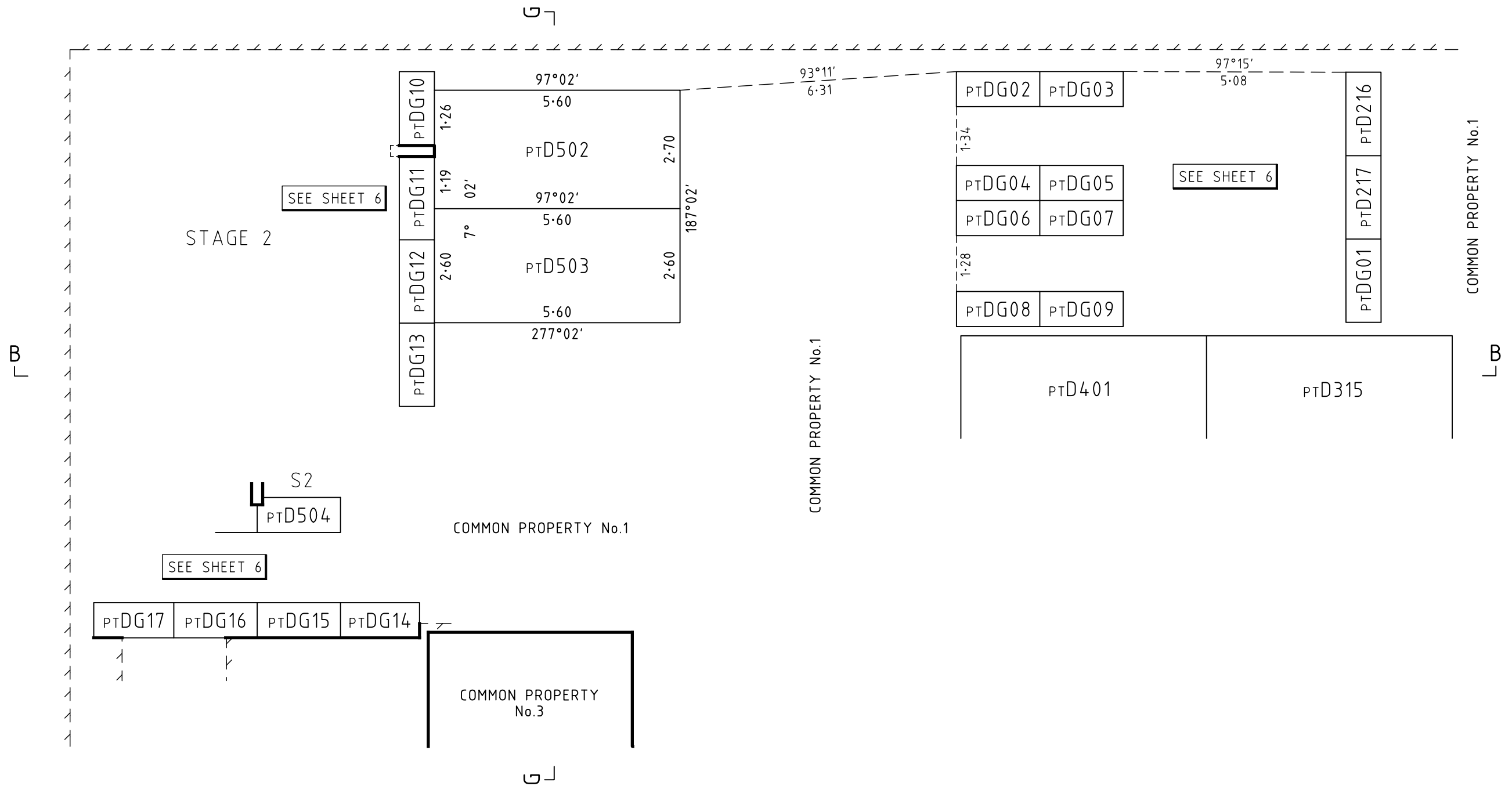

SURVEYOR'S REF: J023976/S3

CHARTER.
KECK CRAMER

Level 19/8 Exhibition Street, Melbourne Victoria 3000
Telephone 03 8102 8888 www.charterkc.com.au

SCALE
1:100



ORIGINAL SHEET SIZE: A3

SHEET 5

KEVIN J. BARGE LS

VERSION 13

DIAGRAM 4A

BASEMENT LEVEL - ENLARGEMENT 2

MGA94 ZONE 55
N

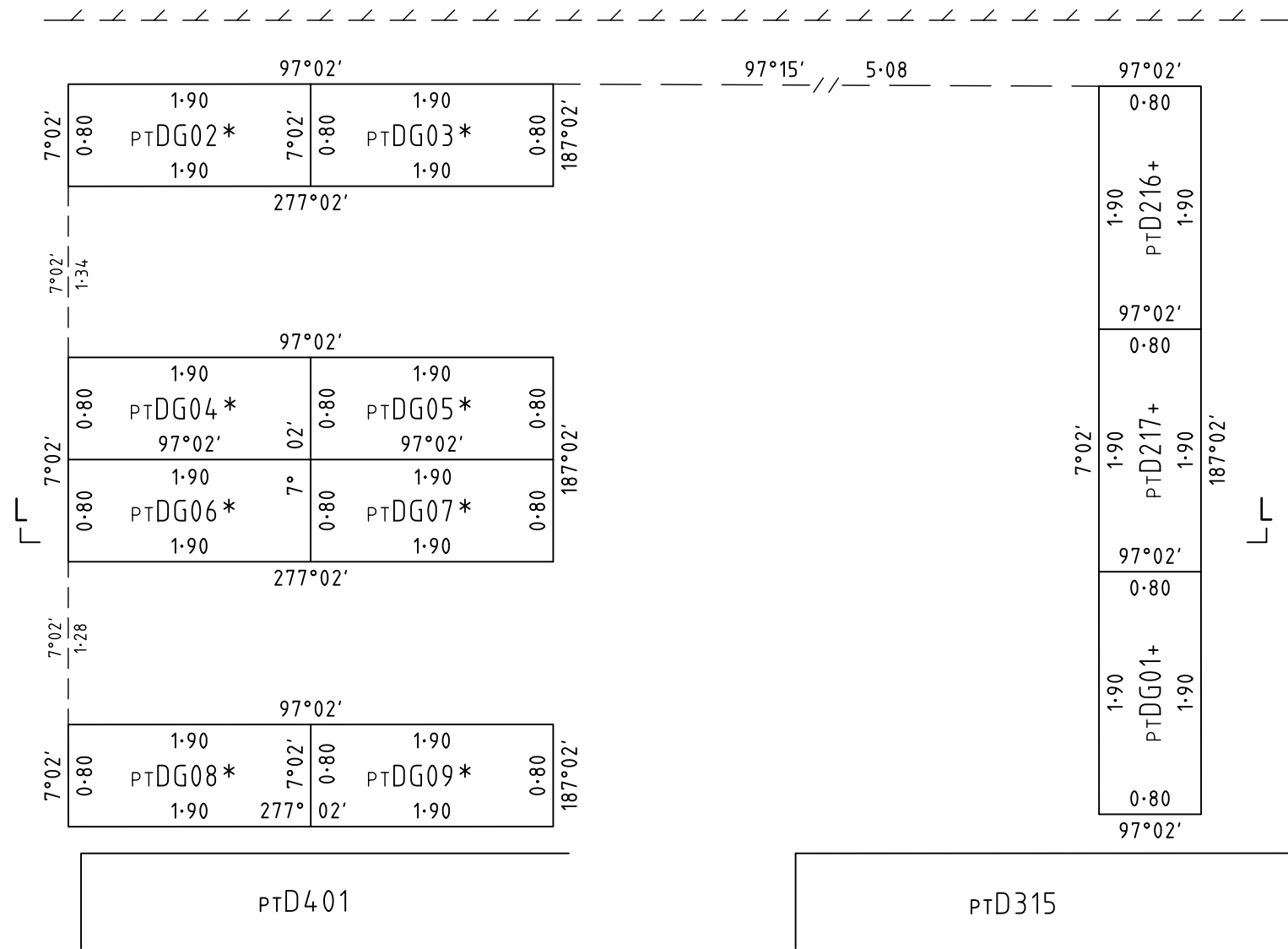
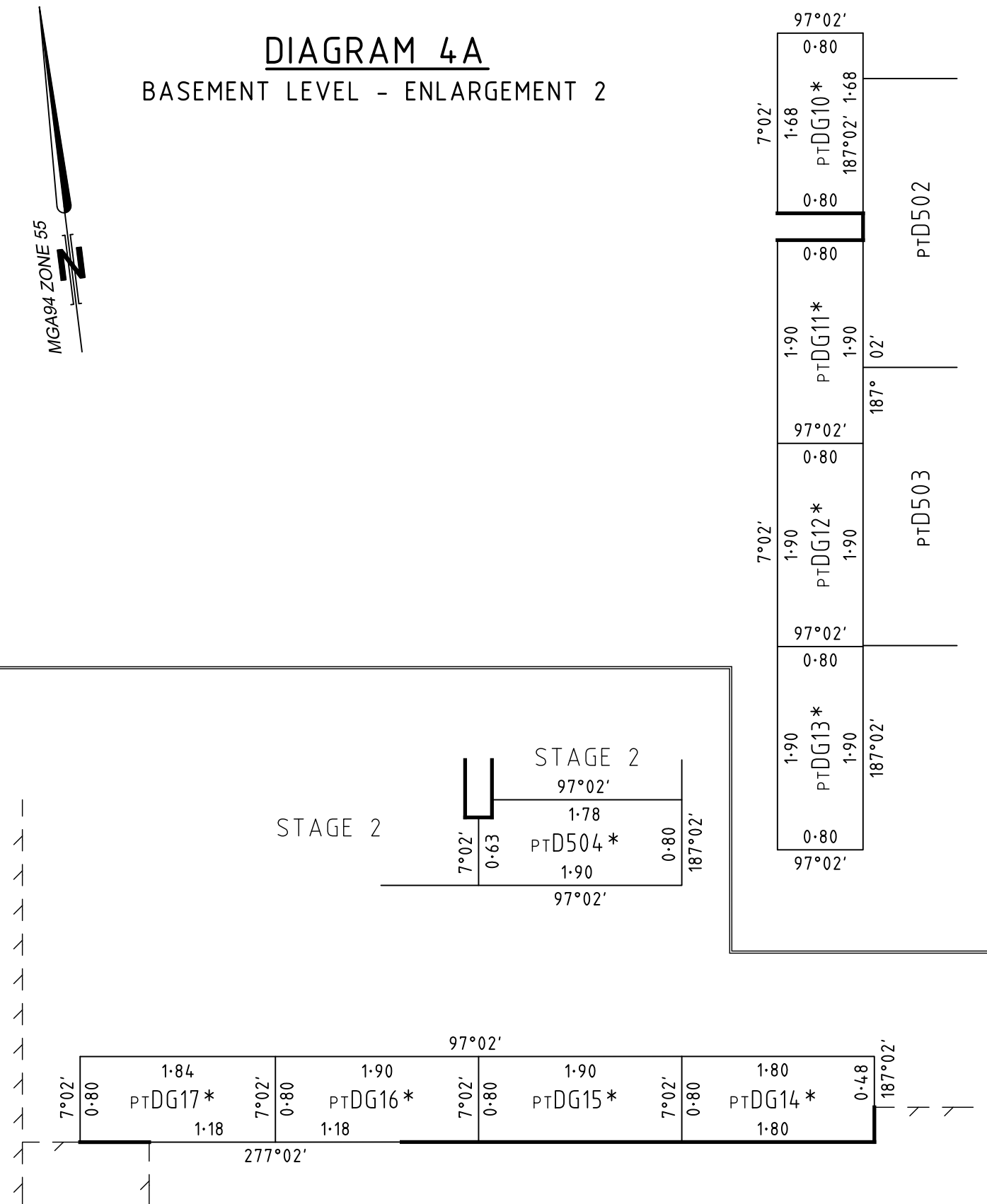

SURVEYOR'S REF: J023976/S3

CHARTER.
KECK CRAMER

Level 19/8 Exhibition Street, Melbourne Victoria 3000
Telephone 03 8102 8888 www.charterkc.com.au

SCALE
1:50



ORIGINAL SHEET SIZE: A3

SHEET 6

KEVIN J. BARGE LS

VERSION 13

DIAGRAM 5
LOWER GROUND LEVEL

SEE SHEET 8 FOR FURTHER
DETAILS OF LOTS ON THIS SHEET

MGA94 ZONE 55

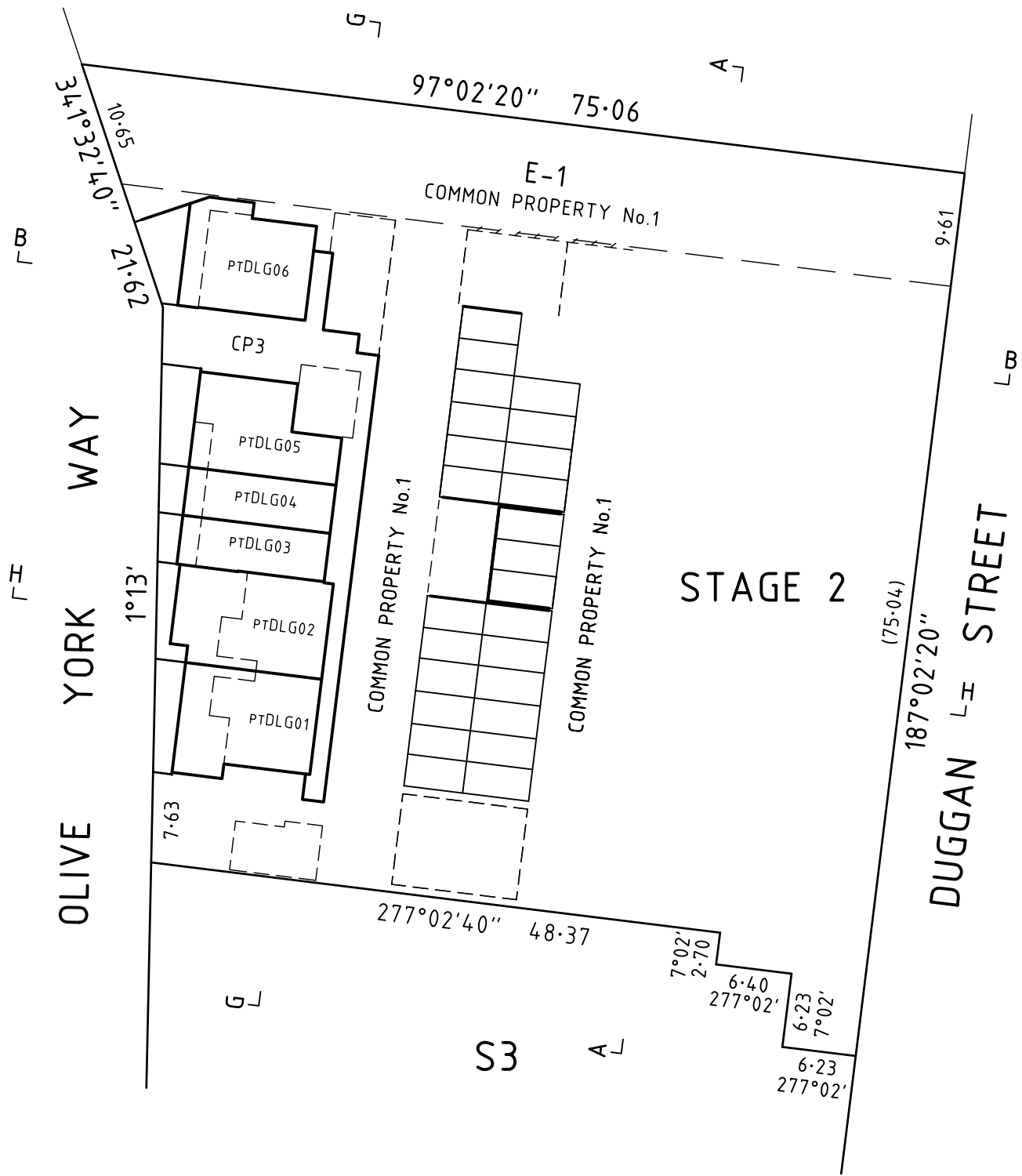

SURVEYOR'S REF: J023976/S3

CHARTER.
KECK CRAMER

Level 19/8 Exhibition Street, Melbourne Victoria 3000
Telephone 03 8102 8888 www.charterkc.com.au

SCALE
1:500

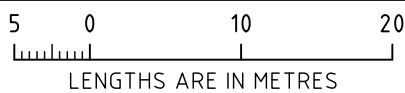

ORIGINAL SHEET SIZE: A3

SHEET 7

KEVIN J. BARGE LS

VERSION 13

DIAGRAM 6

LOWER GROUND LEVEL - ENLARGEMENT

PS 728974W/S3

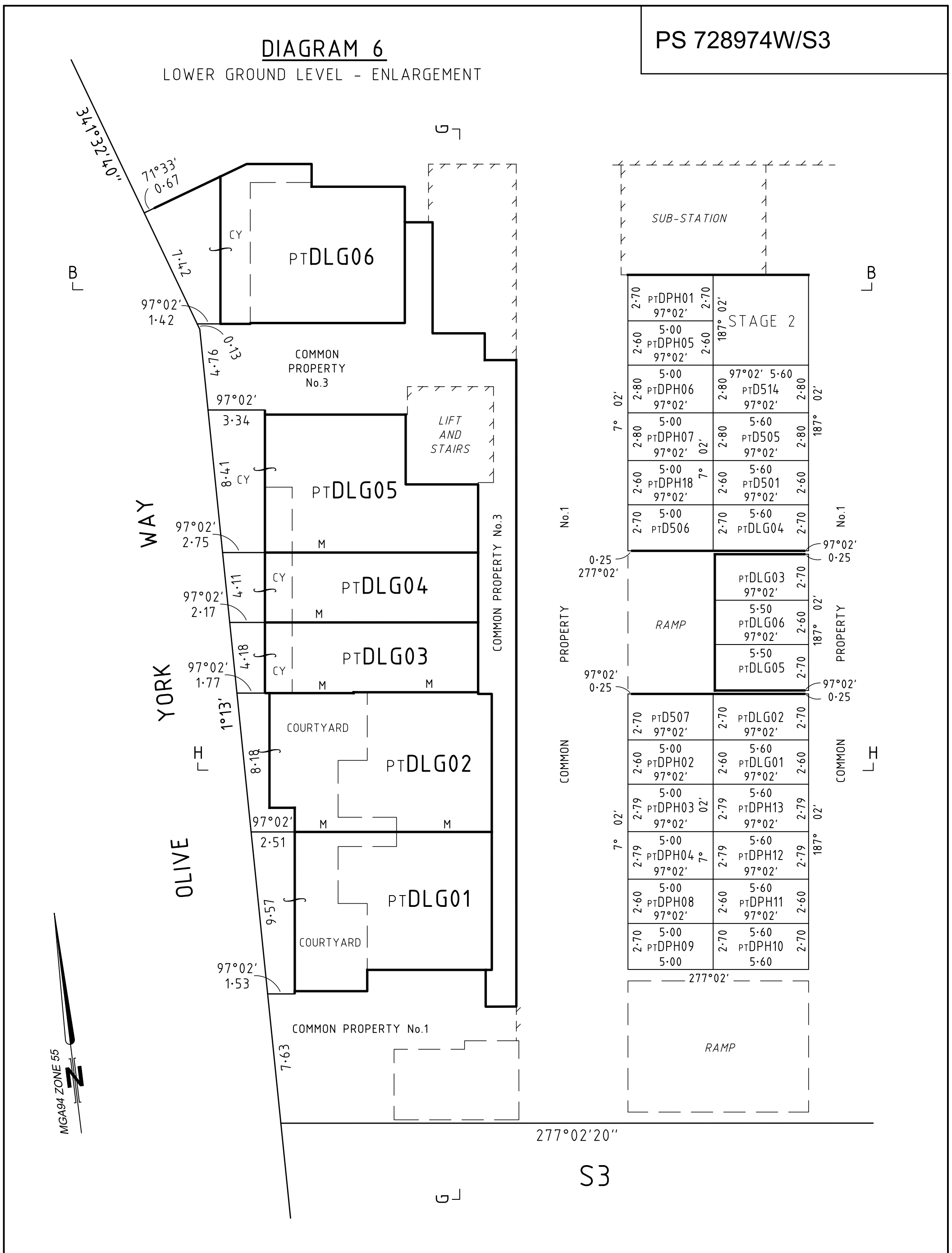

SURVEYOR'S REF: J023976/S3	SCALE 1:200	<p>LENGTHS ARE IN METRES</p>	ORIGINAL SHEET SIZE: A3	SHEET 8
<p>CHARTER. KECK CRAMER</p> <p>Level 19/8 Exhibition Street, Melbourne Victoria 3000 Telephone 03 8102 8888 www.charterkc.com.au</p>		<p>KEVIN J. BARGE LS VERSION 13</p>		

DIAGRAM 7
GROUND LEVEL & GROUND STOREY

SEE SHEET 10 FOR FURTHER
DETAILS OF LOTS ON THIS SHEET

MGA94 ZONE 55

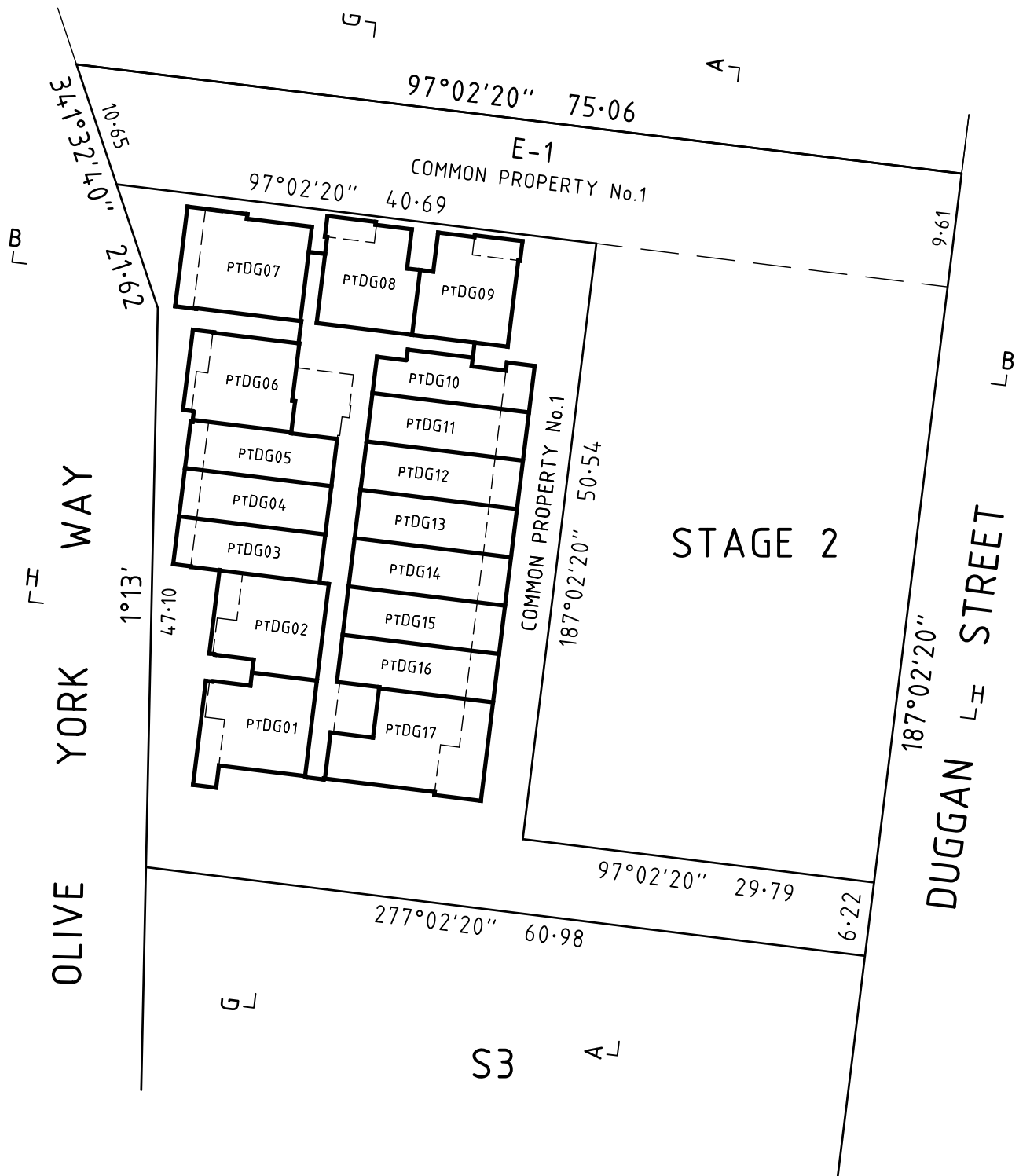

SURVEYOR'S REF: J023976/S3

CHARTER.
KECK CRAMER

Level 19/8 Exhibition Street, Melbourne Victoria 3000
Telephone 03 8102 8888 www.charterkc.com.au

SCALE
1:500

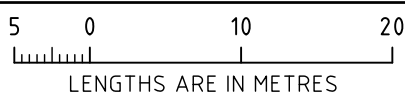

ORIGINAL SHEET SIZE: A3

SHEET 9

KEVIN J. BARGE LS
VERSION 13

DIAGRAM 8

GROUND LEVEL & GROUND STOREY - ENLARGEMENT

MGA94 ZONE 55



SURVEYOR'S REF: J023976/S3

CHARTER.
KECK CRAMER

Level 19/8 Exhibition Street, Melbourne Victoria 3000
Telephone 03 8102 8888 www.charterkc.com.au

SCALE
1:250



ORIGINAL SHEET SIZE: A3

SHEET 10

KEVIN J. BARGE LS
VERSION 13

DIAGRAM 9

LEVEL 1

PS 728974W/S3

MGA94 ZONE 55



SURVEYOR'S REF: J023976/S3

CHARTER.
KECK CRAMER

Level 19/8 Exhibition Street, Melbourne Victoria 3000
Telephone 03 8102 8888 www.charterkc.com.au

SCALE
1:250



ORIGINAL SHEET SIZE: A3

SHEET 11

KEVIN J. BARGE LS
VERSION 13

DIAGRAM 10

LEVEL 2

MGA94 ZONE 55



SURVEYOR'S REF: J023976/S3

CHARTER.
KECK CRAMER

Level 19/8 Exhibition Street, Melbourne Victoria 3000
Telephone 03 8102 8888 www.charterkc.com.au

SCALE
1:250



ORIGINAL SHEET SIZE: A3

SHEET 12

KEVIN J. BARGE LS
VERSION 13

DIAGRAM 11

LEVEL 3

MGA94 ZONE 55



SURVEYOR'S REF: J023976/S3

CHARTER.
KECK CRAMER

Level 19/8 Exhibition Street, Melbourne Victoria 3000
Telephone 03 8102 8888 www.charterkc.com.au

SCALE
1:250

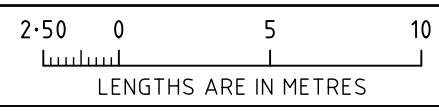

ORIGINAL SHEET SIZE: A3

SHEET 13

KEVIN J. BARGE LS
VERSION 13

DIAGRAM 12

LEVEL 4

MGA94 ZONE 55



OLIVE WAY YORK WAY

STAGE 2

SURVEYOR'S REF: J023976/S3

CHARTER.
KECK CRAMER

Level 19/8 Exhibition Street, Melbourne Victoria 3000
Telephone 03 8102 8888 www.charterkc.com.au

SCALE
1:250



ORIGINAL SHEET SIZE: A3

SHEET 14

KEVIN J. BARGE LS
VERSION 13

DIAGRAM 13

LEVEL 5

PS 728974W/S3

MGA94 ZONE 55

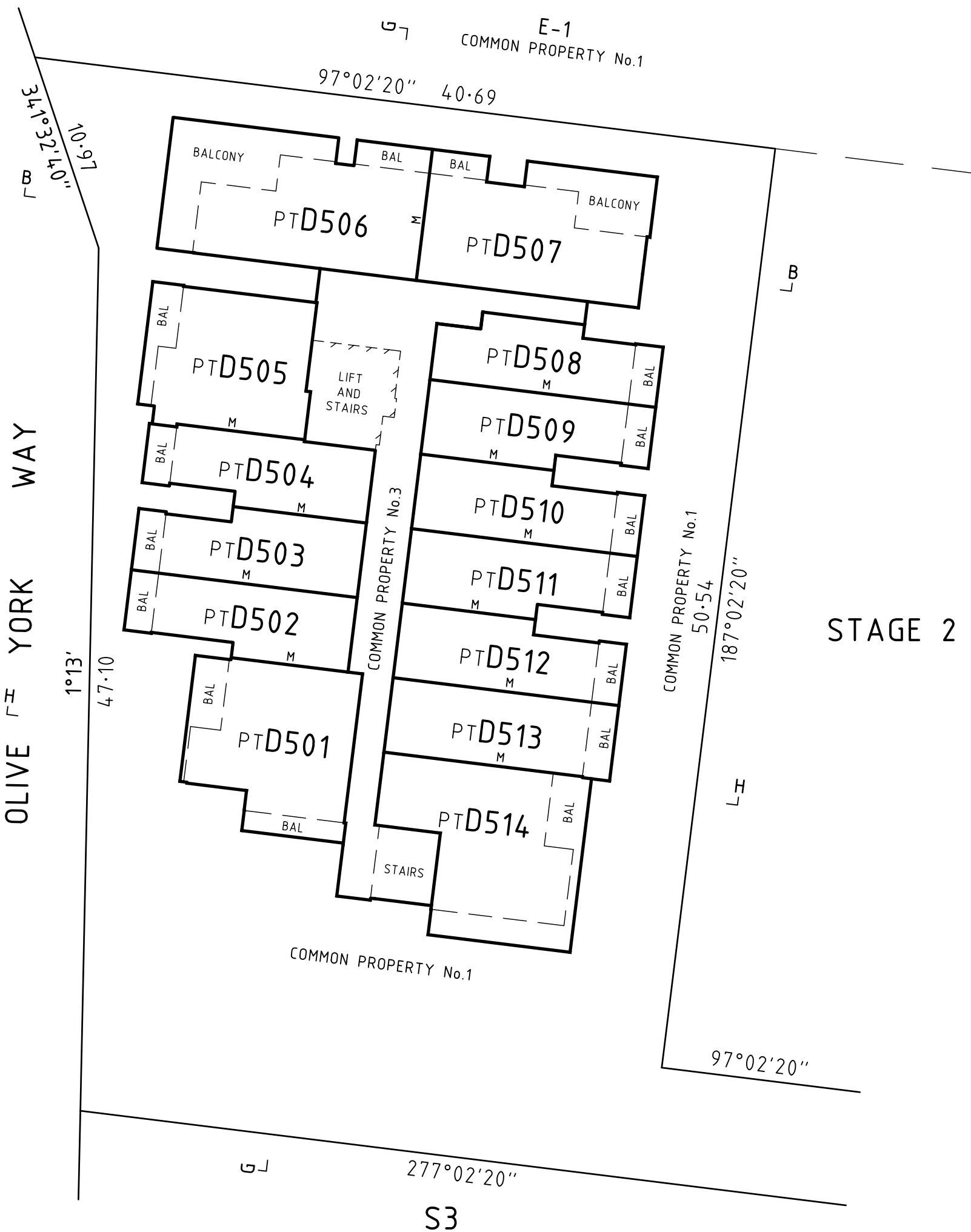

SURVEYOR'S REF: J023976/S3

CHARTER.
KECK CRAMER

Level 19/8 Exhibition Street, Melbourne Victoria 3000
Telephone 03 8102 8888 www.charterkc.com.au

SCALE
1:250



ORIGINAL SHEET SIZE: A3

SHEET 15

KEVIN J. BARGE LS
VERSION 13

DIAGRAM 14

LEVEL 6

MGA94 ZONE 55

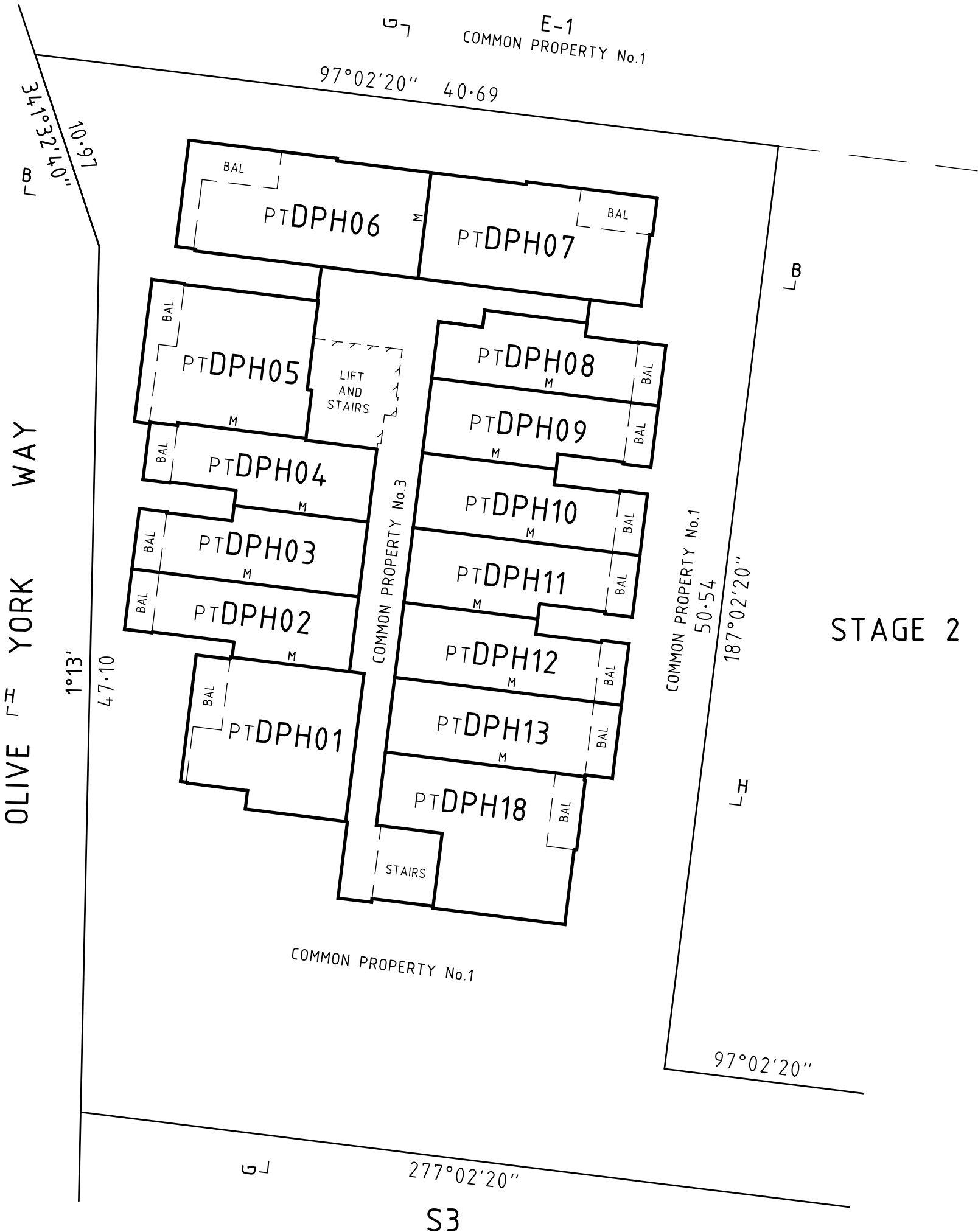

SURVEYOR'S REF: J023976/S3

CHARTER.
KECK CRAMER

Level 19/8 Exhibition Street, Melbourne Victoria 3000
Telephone 03 8102 8888 www.charterkc.com.au

SCALE
1:250



ORIGINAL SHEET SIZE: A3

SHEET 16

KEVIN J. BARGE LS
VERSION 13

BASEMENT LEVEL
(DIAGRAMS 1, 2, & 3)

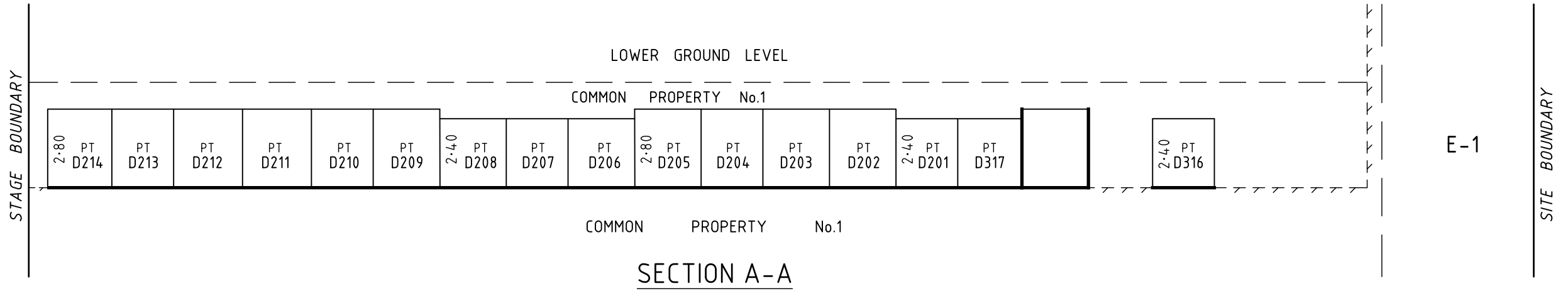

BASEMENT LEVEL
(DIAGRAMS 1, 2, & 3)

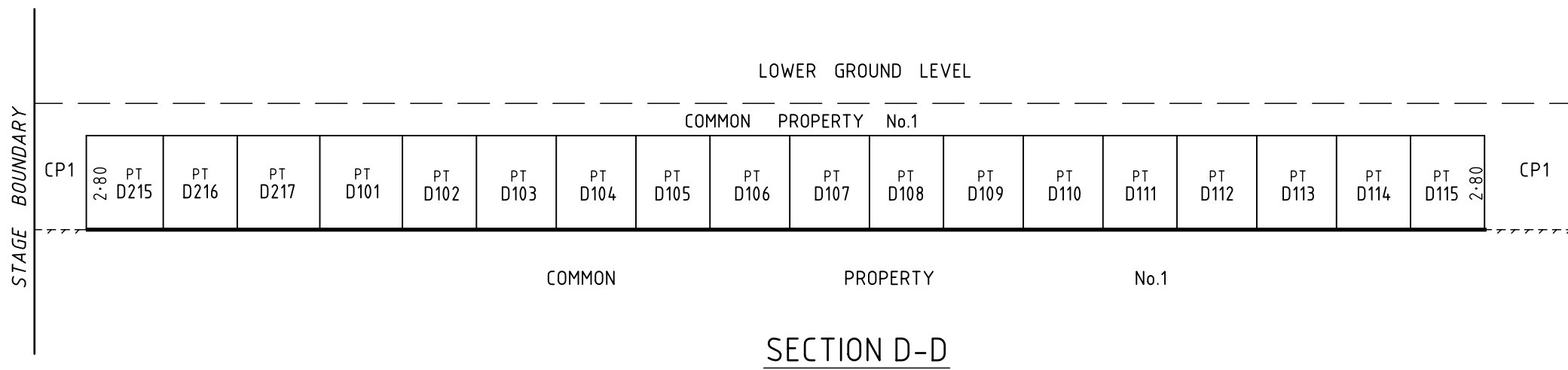

BASEMENT LEVEL
(DIAGRAMS 1, 2, & 3)

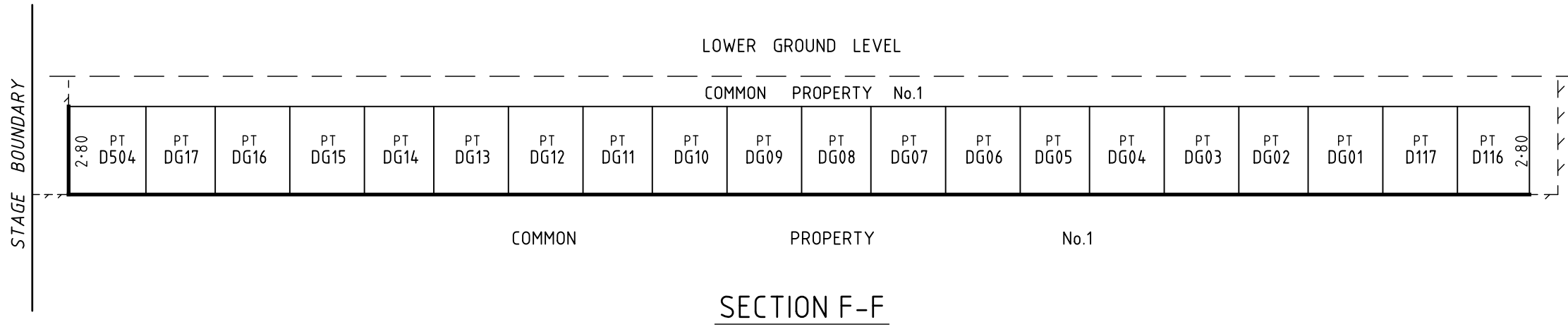

SURVEYOR'S REF: J023976/S3

CHARTER.
KECK CRAMER

Level 19/8 Exhibition Street, Melbourne Victoria 3000
Telephone 03 8102 8888 www.charterkc.com.au

SCALE

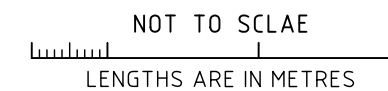

ORIGINAL SHEET SIZE: A3

SHEET 17

KEVIN J. BARGE LS

VERSION 13

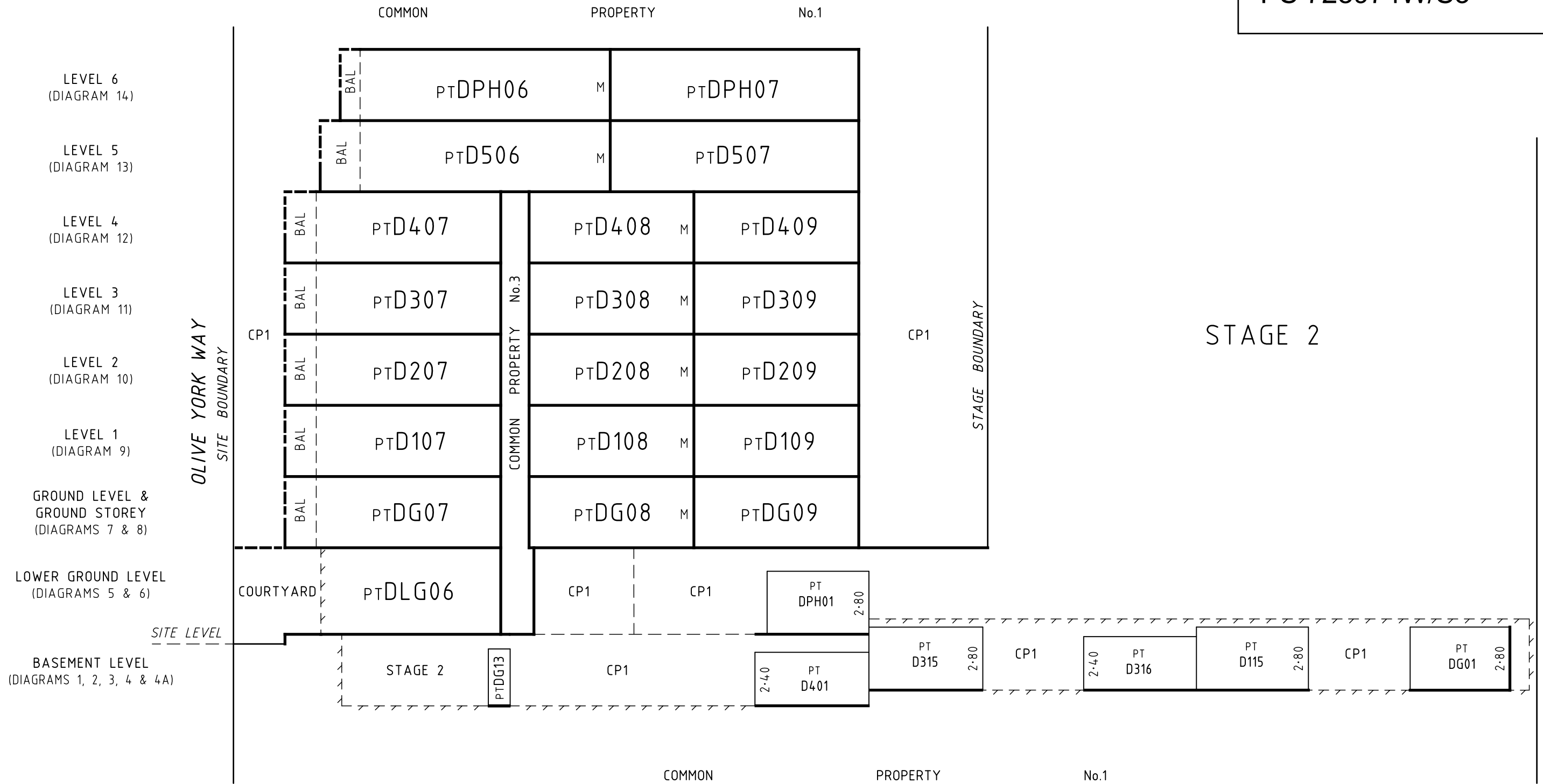

SECTION B-B
 TYPICAL FOR ALL LOTS AT EACH LEVEL
 UNLESS OTHERWISE SHOWN OR NOTED

SURVEYOR'S REF: J023976/S3

CHARTER.
 KECK CRAMER

Level 19/8 Exhibition Street, Melbourne Victoria 3000
 Telephone 03 8102 8888 www.charterkc.com.au

SCALE

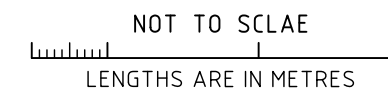

ORIGINAL SHEET SIZE: A3

SHEET 18

KEVIN J. BARGE LS

VERSION 13

COMMON PROPERTY No.1

LEVEL 6
(DIAGRAM 14)

LEVEL 5
(DIAGRAM 13)

LEVEL 4
(DIAGRAM 12)

LEVEL 3
(DIAGRAM 11)

LEVEL 2
(DIAGRAM 10)

LEVEL 1
(DIAGRAM 9)

GROUND LEVEL &
GROUND STOREY
(DIAGRAMS 7 & 8)

LOWER GROUND LEVEL
(DIAGRAMS 5 & 6)

BASEMENT LEVEL
(DIAGRAMS 1, 2, 3, 4 & 4A)

S3

STAGE BOUNDARY

COMMON
PROPERTY
No.1

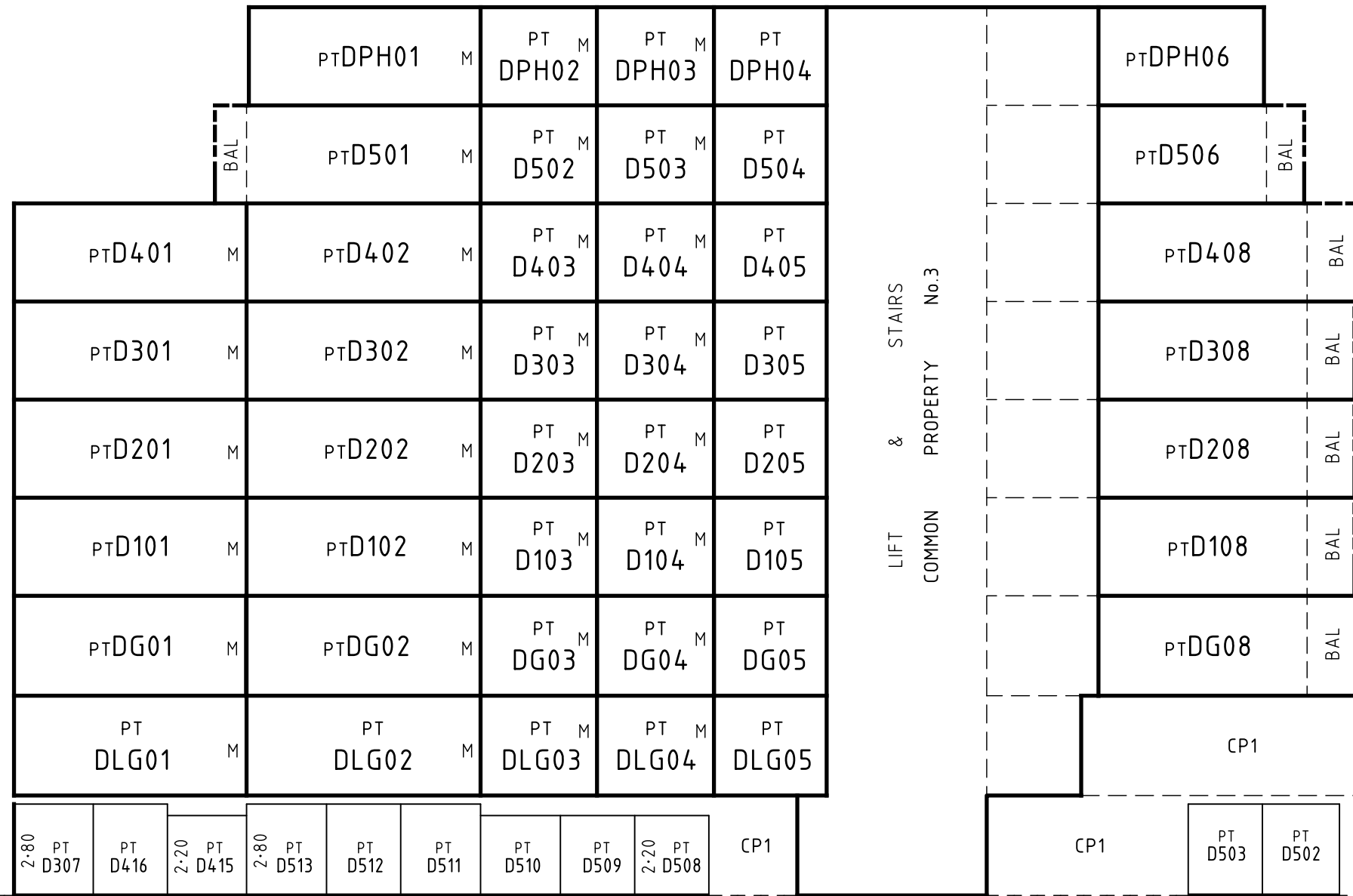

E-1

SITE BOUNDARY

SITE LEVEL

COMMON PROPERTY No.1

SECTION G-G

TYPICAL FOR ALL LOTS AT EACH LEVEL
UNLESS OTHERWISE SHOWN OR NOTED

SURVEYOR'S REF: J023976/S3

CHARTER.
KECK CRAMER

Level 19/8 Exhibition Street, Melbourne Victoria 3000
Telephone 03 8102 8888 www.charterkc.com.au

SCALE

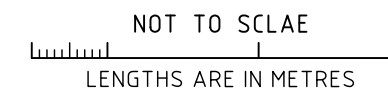

ORIGINAL SHEET SIZE: A3

SHEET 19

KEVIN J. BARGE LS

VERSION 13

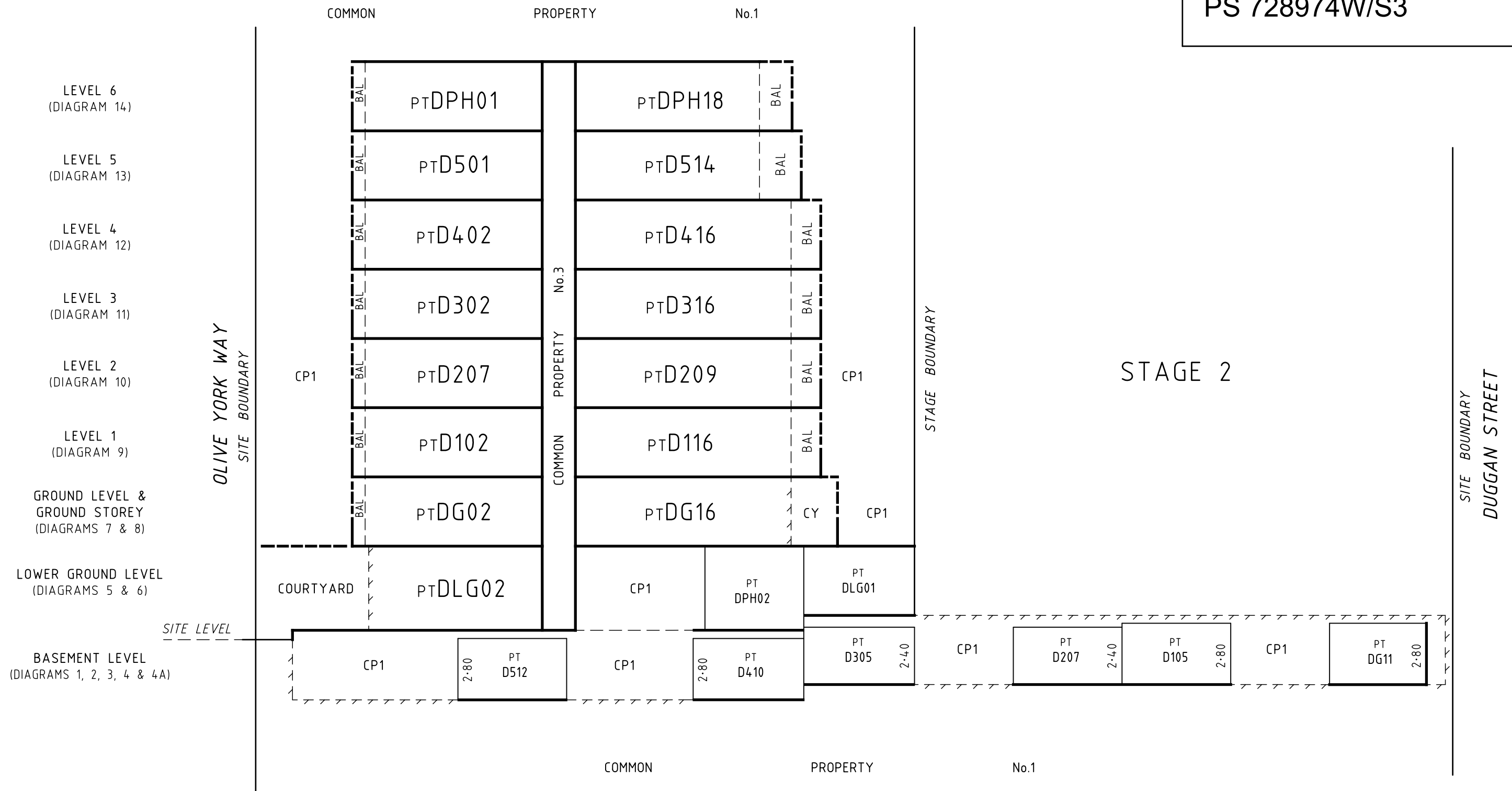

SECTION H-H

TYPICAL FOR ALL LOTS AT EACH LEVEL
UNLESS OTHERWISE SHOWN OR NOTED

SURVEYOR'S REF: J023976/S3		SCALE -	NOT TO SCALE LENGTHS ARE IN METRES	ORIGINAL SHEET SIZE: A3	SHEET 20
<p>CHARTER. KECK CRAMER Level 19/8 Exhibition Street, Melbourne Victoria 3000 Telephone 03 8102 8888 www.charterkc.com.au</p>		<p>KEVIN J. BARGE LS VERSION 13</p>			

BASEMENT LEVEL
(DIAGRAMS 1, 2, & 3)

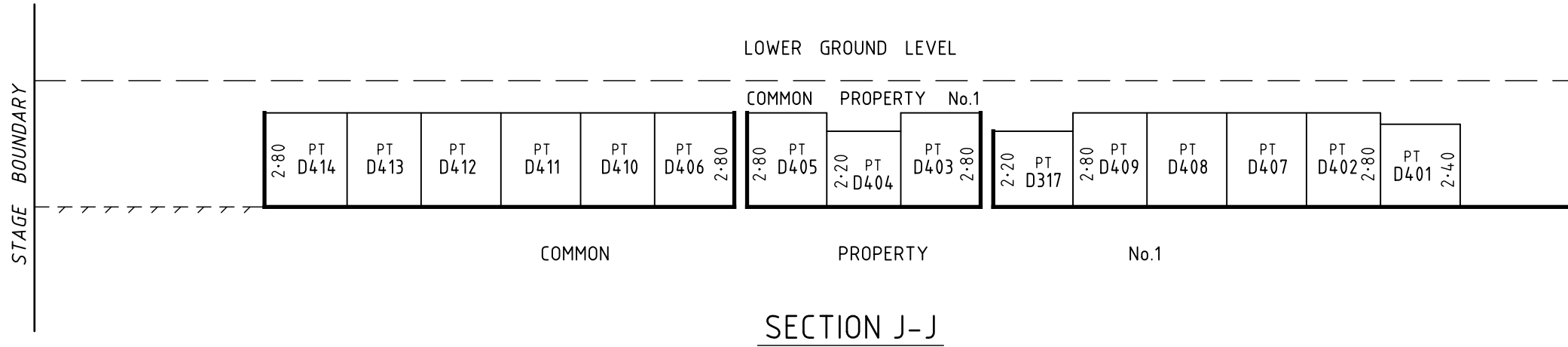

SECTION J-J

BASEMENT LEVEL
(DIAGRAMS 1, 2, & 3)

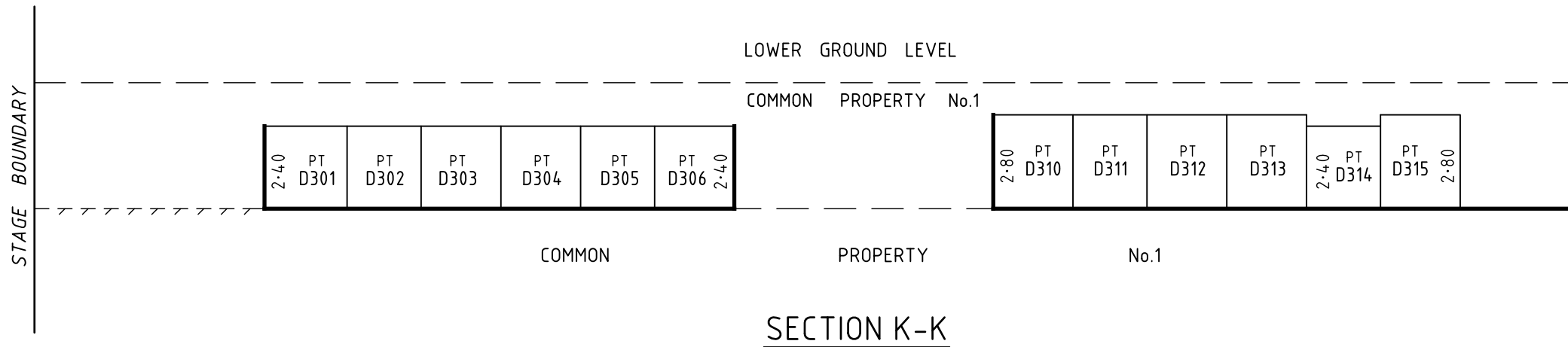

SECTION K-K

BASEMENT LEVEL
(DIAGRAMS 1, 2, 3, 4 & 4A)

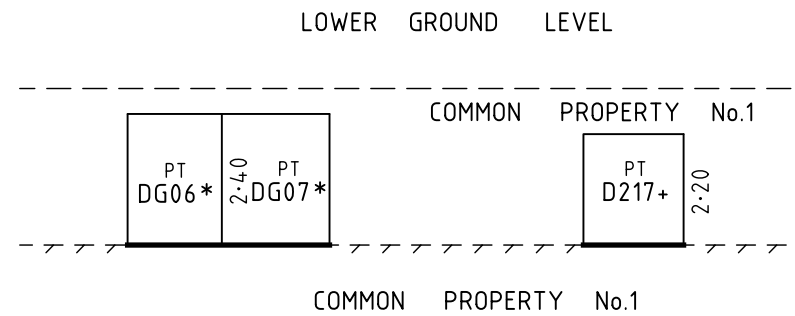

SECTION L-L

TYPICAL HEIGHT LIMITS FOR
LOTS MARKED * AND +
IN DIAGRAM 4A

SURVEYOR'S REF: J023976/S3

CHARTER.
KECK CRAMER

Level 19/8 Exhibition Street, Melbourne Victoria 3000
Telephone 03 8102 8888 www.charterkc.com.au

SCALE

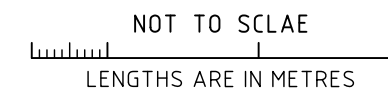

ORIGINAL SHEET SIZE: A3

SHEET 21

KEVIN J. BARGE LS

VERSION 13

OWNERS CORPORATION SCHEDULE

PS728974W

Owners Corporation No. 1 Plan No. PS728974W

Land affected by Owners Corporation Lots: ALL OF THE LOTS IN THE TABLE BELOW

Common Property No.: 1, 3

Limitations of Owners Corporation: UNLIMITED

Notations
ONLY THE MEMBERS OF OWNERS CORPORATION NO. 3 ARE ENTITLED TO USE COMMON PROPERTY NO. 3

Totals		
	Entitlement	Liability
This schedule	37360	21170
Previous stages	0	0
Overall Total	37360	21170

Lot Entitlement and Lot Liability

Lot	Entitlement	Liability	Lot	Entitlement	Liability	Lot	Entitlement	Liability	Lot	Entitlement	Liability
(STAGE 2)	6940	6940	D201	140	140	D414	100	100			
			D202	140	140	D415	100	100			
DLG01	140	140	D203	100	100	D416	100	100			
DLG02	140	140	D204	100	100	D417	160	160			
DLG03	100	100	D205	100	100						
DLG04	100	100	D206	140	140	D501	140	140			
DLG05	160	160	D207	160	160	D502	100	100			
DLG06	160	160	D208	140	140	D503	100	100			
			D209	140	140	D504	100	100			
DG01	140	140	D210	100	100	D505	140	140			
DG02	140	140	D211	100	100	D506	160	160			
DG03	100	100	D212	100	100	D507	160	160			
DG04	100	100	D213	100	100	D508	100	100			
DG05	100	100	D214	100	100	D509	100	100			
DG06	140	140	D215	100	100	D510	100	100			
DG07	160	160	D216	100	100	D511	100	100			
DG08	140	140	D217	160	160	D512	100	100			
DG09	140	140				D513	100	100			
DG10	100	100	D301	140	140	D514	160	160			
DG11	100	100	D302	140	140						
DG12	100	100	D303	100	100	DPH01	140	140			
DG13	100	100	D304	100	100	DPH02	100	100			
DG14	100	100	D305	100	100	DPH03	100	100			
DG15	100	100	D306	140	140	DPH04	100	100			
DG16	100	100	D307	160	160	DPH05	140	140			
DG17	160	160	D308	140	140	DPH06	160	160			
			D309	140	140	DPH07	160	160			
D101	140	140	D310	100	100	DPH08	100	100			
D102	140	140	D311	100	100	DPH09	100	100			
D103	100	100	D312	100	100	DPH10	100	100			
D104	100	100	D313	100	100	DPH11	100	100			
D105	100	100	D314	100	100	DPH12	100	100			
D106	140	140	D315	100	100	DPH13	100	100			
D107	160	160	D316	100	100	DPH18	160	160			
D108	140	140	D317	160	160						
D109	140	140				S3	16200	10			
D110	100	100	D401	140	140						
D111	100	100	D402	140	140						
D112	100	100	D403	100	100						
D113	100	100	D404	100	100						
D114	100	100	D405	100	100						
D115	100	100	D406	140	140						
D116	100	100	D407	160	160						
D117	160	160	D408	140	140						
			D409	140	140						
			D410	100	100						
			D411	100	100						
			D412	100	100						
			D413	100	100						

SURVEYORS FILE REFERENCE: J023976

SHEET 1

ORIGINAL SHEET
SIZE: A3

CHARTER.
KECK CRAMER

Level 19/8 Exhibition Street, Melbourne Victoria 3000
Telephone 03 8102 8888 www.charterkc.com.au

KEVIN J. BARGE LS
VERSION 13

OWNERS CORPORATION SCHEDULE

PS728974W

Owners Corporation No. 3 Plan No. PS728974W

Land affected by Owners Corporation Lots: ALL OF THE LOTS IN THE TABLE BELOW

Common Property No.: 3

Limitations of Owners Corporation: LIMITED TO COMMON PROPERTY

Notations

MEMBERS OF OWNERS CORPORATION NO. 3 ARE ALSO AFFECTED BY OWNERS CORPORATION NO. 1
 FOLIO OF THE REGISTER FOR COMMON PROPERTY NO. 3 IS IN THE NAME OF OWNERS CORPORATION NO. 1

Totals		
	Entitlement	Liability
This schedule	14220	14220
Previous stages	0	0
Overall Total	14220	14220

Lot Entitlement and Lot Liability

Lot	Entitlement	Liability	Lot	Entitlement	Liability	Lot	Entitlement	Liability	Lot	Entitlement	Liability
DLG01	140	140	D201	140	140	D414	100	100			
DLG02	140	140	D202	140	140	D415	100	100			
DLG03	100	100	D203	100	100	D416	100	100			
DLG04	100	100	D204	100	100	D417	160	160			
DLG05	160	160	D205	100	100						
DLG06	160	160	D206	140	140	D501	140	140			
			D207	160	160	D502	100	100			
DG01	140	140	D208	140	140	D503	100	100			
DG02	140	140	D209	140	140	D504	100	100			
DG03	100	100	D210	100	100	D505	140	140			
DG04	100	100	D211	100	100	D506	160	160			
DG05	100	100	D212	100	100	D507	160	160			
DG06	140	140	D213	100	100	D508	100	100			
DG07	160	160	D214	100	100	D509	100	100			
DG08	140	140	D215	100	100	D510	100	100			
DG09	140	140	D216	100	100	D511	100	100			
DG10	100	100	D217	160	160	D512	100	100			
DG11	100	100				D513	100	100			
DG12	100	100	D301	140	140	D514	160	160			
DG13	100	100	D302	140	140						
DG14	100	100	D303	100	100	DPH01	140	140			
DG15	100	100	D304	100	100	DPH02	100	100			
DG16	100	100	D305	100	100	DPH03	100	100			
DG17	160	160	D306	140	140	DPH04	100	100			
			D307	160	160	DPH05	140	140			
D101	140	140	D308	140	140	DPH06	160	160			
D102	140	140	D309	140	140	DPH07	160	160			
D103	100	100	D310	100	100	DPH08	100	100			
D104	100	100	D311	100	100	DPH09	100	100			
D105	100	100	D312	100	100	DPH10	100	100			
D106	140	140	D313	100	100	DPH11	100	100			
D107	160	160	D314	100	100	DPH12	100	100			
D108	140	140	D315	100	100	DPH13	100	100			
D109	140	140	D316	100	100	DPH18	160	160			
D110	100	100	D317	160	160						
D111	100	100									
D112	100	100	D401	140	140						
D113	100	100	D402	140	140						
D114	100	100	D403	100	100						
D115	100	100	D404	100	100						
D116	100	100	D405	100	100						
D117	160	160	D406	140	140						
			D407	160	160						
			D408	140	140						
			D409	140	140						
			D410	100	100						
			D411	100	100						
			D412	100	100						
			D413	100	100						

SURVEYORS FILE REFERENCE: J023976

SHEET 2

ORIGINAL SHEET SIZE: A3

CHARTER.
KECK CRAMER

Level 19/8 Exhibition Street, Melbourne Victoria 3000
 Telephone 03 8102 8888 www.charterkc.com.au

KEVIN J. BARGE LS
 VERSION 13